

VULKAN



TECHNICAL DATA TECHNISCHE DATEN

VULASTIK XT

0,56 kNm

38,60 kNm

TORQUE RANGE DREHMOMENT

CONTENTS INHALT



INTRODUCTION	3	PERFORMANCE DATA	22	GEOMETRIC DATA	25		
EINFÜHRUNG		LEISTUNGSDATEN		GEOMETRISCHE DATEN			
Characteristics		Material Natural Rubber		Series 2800		Online-Service	
Eigenschaften	10	Material Gummi	22	Baureihe 2800	25	Online-Service	35
Design variants				Series 2802		Validity Clause	
Designvarianten	12			Baureihe 2802	28	Gültigkeitsklausel	36
Coupling selection				Series 2804			
Kupplungsauswahl	13			Baureihe 2804	31		
Explanations of the product code				Series 2810			
Erläuterung des Produktcodes	14			Baureihe 2810	33		
Explanations of the technical data							
Erläuterung der technischen Daten	15						
Summary of Series							
Baureihenübersicht	20						

The VULKAN Group, into which the VULKAN company founded in 1889 is integrated today, is composed of three brands: VULKAN Couplings, VULKAN Drive Tech and VULKAN Lokring. The VULKAN Group is owned and managed by the Hackforth family – now in its fourth generation.

Our global presence makes it possible for us to provide our customers with fast, customized solutions on site, a decisive competitive advantage. Our 1,200 employees work at 18 sites around the world; our customers can also find a personal contact in our VULKAN agencies covering 51 countries. For our customers this means that our specialists and the matching solutions are quickly available right where they are needed.

Die VULKAN Gruppe, in die heute die 1889 gegründete Firma VULKAN integriert ist, setzt sich aus den drei Unternehmensbereichen VULKAN Couplings, VULKAN Drive Tech und VULKAN Lokring zusammen.

Unsere globale Präsenz versetzt uns in die Lage, unseren Kunden vor Ort schnelle und maßgeschneiderte Lösungen anzubieten, ein entscheidender Wettbewerbsvorteil. Unsere rund 1.200 Mitarbeiter arbeiten an 18 Standorten weltweit, zusätzlich finden unsere Kunden ihre Ansprechpartner in unseren Vertretungen in 51 Ländern der Erde. Für unsere Kunden heißt das: Unsere Spezialisten und die passenden Lösungen sind schnell und auf kurzen Wegen verfügbar – da, wo sie gebraucht werden.







MARINE APPLICATIONS

VULKAN flexible couplings are used on nearly all types of ships with diesel mechanic or diesel electric drive concepts. Large cruise ships such as the Aida Stella, workboats such as the ice-breaking drill ship Stena Icemax or the jack-up vessel Innovation and boats for leisure activities can all benefit from the outstandingly dynamic properties and the long product lifetime of the couplings made in one of our production locations.



CARGO VESSELS

Bulker / Tanker / Container / Dry Cargo / LNG

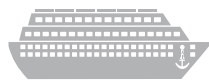

PASSENGER SHIPS

Cruise Ships / Ro-Pax Ferries / Fast Ferries



PLEASURE BOATS

Yachts / Mega Yachts



WORK BOATS

Tug Boat / Offshore Support Vessel / Fishing Vessel / Icebreakers / Dredger



SPECIAL VESSELS

Navy / Production Storage and Offloading / Heavy Lift Vessel



AUXILIARY DRIVES

Generator

FRACHTER

Schüttgutfrachter / Tanker / Containerschiff / Trockengutfrachter / LNG

PASSAGIERSCHIFFE

Kreuzfahrtschiff / Ro-Pax Fähre / schnelle Fähre

SPORTBOOTE

Yacht / Mega Yacht

ARBEITSBOOTE

Schlepper / Offshore Versorger / Fischereischiff / Eisbrecher / Baggerschiff

SPECIAL VESSELS

Navy / Production Storage and Offloading / Schwergutschiff

NEBENANTRIEBE

Generator

MARINE ANWENDUNGEN

Elastische Kupplungen von VULKAN werden in fast allen Schiffstypen mit dieselmechanischen oder dieselelektrischen Antriebskonzepten eingesetzt. Große Kreuzfahrtschiffe wie die Aida Stella, Arbeitsboote wie das eisbrechende Bohrschiff Stena Icemax oder das Hubschiff Innovation und Boote für Freizeitaktivitäten können alle von den herausragenden dynamischen Eigenschaften und der langen Lebensdauer der an einem unserer Produktionsstandorte hergestellten Kupplungen profitieren.





INDUSTRIAL APPLICATIONS

VULKAN Drive Tech offers a range of solutions for industrial drives and brake systems. Hereby the technical know-how is centered on more than 20 different application types within six different industrial market segments.

INDUSTRIEANWENDUNGEN

VULKAN Drive Tech bietet eine Reihe von Lösungen für industrielle Antriebe und Bremsysteme. Dabei konzentriert sich das technische Know-how auf mehr als 20 unterschiedliche Anwendungstypen innerhalb von sechs unterschiedlichen Marktsegmenten des Industriesektors.



OIL & GAS

Compressors / Blowers /
Pumps / Fans



MINING

Belt Conveyors / Stackers /
Reclaimers / Crushers / Mills /
Separators / Agitators



BULK MATERIAL HANDLING

E.O.T. Cranes / Construction and
Mobile Machinery



IRON & STEEL

Casting and Lamination Machinery



RENEWABLE ENERGY

Hydro and Wind Generators



GENERAL MACHINERY

Test Benches

ÖL & GAS

Kompressoren / Gebläse /
Pumpen / Lüfter

BERGBAU

Gurtbandförderer / Absetzer /
Rücklader / Brecher / Mühlen /
Abschneider / Rührwerke

FÖRDERTECHNIK

Laufkräne / Baumaschinen und
mobile Maschinen

EISEN & STAHL

Guss- und Laminiermaschinen

ERNEUERBARE ENERGIE

Wasserkraft- und
Windenergieanlagen

ALLGEMEINE MASCHINEN

Prüfstände





STATIONARY POWER PLANTS

VULKAN couplings are found in stationary power plants used for permanent, temporary or emergency power supply. Generator couplings from VULKAN have always been the first choice for highly flexible coupling of diesel motors with generators.



GENERATOR SETS

GENERATORANLAGEN

STATIONÄRE STROMERZEUGUNGSANLAGEN

VULKAN Kupplungen finden in stationären Stromerzeugungsanlagen, im Dauerbetrieb zur permanenten, im Grundleistungsbetrieb zur temporären Stromversorgung und im Bereitschaftsbetrieb zur Notstromversorgung Verwendung. Generatorkupplungen von VULKAN sind seit jeher erste Wahl, wenn es um die hochelastische Kopplung von Dieselmotoren mit Generatoren geht.





TORQUE DREHMOMENT 0,56 kNm – 38,60 kNm

Areas of Application

Industrial Applications as alternators, compressors and bell housing applications.

The VULASTIK XT is an axial pluggable coupling for non classification relevant applications. Six rubber qualities are available in order to tune the coupling to the various system requirements. The VULASTIK XT can be axially plugged in due to its teeth profile on the outer radius of the element and due to its vulcanized connection at the inner radius of the element. The VULASTIK XT is specially designed for industrial applications and its lean design gives clear commercial benefits. A special design for alternator applications, especially in the stiffness classes 6, 8 and A allows an optimized thermal usage resulting in a very high permissible power loss.

Benefits

- ⊕ Low investment costs thanks to its lean design
- ⊕ Highest solution flexibility due to different coupling designs for installation in bellhoused installations or free-standing installations
- ⊕ Optimized system tuning provided by six different rubber qualities
- ⊕ Easy assembling due to its axial plug-in feature
- ⊕ High permissible power loss and therefore a high solution flexibility in alternator applications

Einsatzgebiete

Industrielle Anwendungen wie Generatoren, Kompressoren und allgemein Glockeneinbauten.

Die VULASTIK XT ist eine axiale steckbare Kupplung für nicht abnahmerelevante Anwendungen. Zur Anpassung der VULASTIK XT an die verschiedenen Systemanforderungen stehen sechs verschiedene Gummimischungen zur Verfügung. Die VULASTIK XT zeichnet sich durch die axiale Steckbarkeit aus, die durch die Zahngeometrie am Außenradius und durch das anvulkanisierte Elastomer am Innenradius des Elements gewährleistet wird. Die VULASTIK XT ist spezifisch für industrielle Anwendungen entwickelt und bietet durch das optimierte Design entscheidende Kostenvorteile. Die Ausführung für Generatoranwendungen in den Steifigkeiten 6, 8 und A ermöglicht weiterhin eine optimale thermische Ausnutzung der Elemente für hohe Verlustleistungswerte und entsprechend eine weitreichende Einsetzbarkeit.

Produktvorteile

- ⊕ Geringe Investitionskosten dank optimierten Design
- ⊕ Maximale Lösungsflexibilität durch verschiedene Kupplungsausführungen für Glockeneinbau oder freistehende Installation
- ⊕ Optimale Systemabstimmung durch sechs Gummiquitäten
- ⊕ Einfache Montage dank axialer Steckbarkeit
- ⊕ Hohe Verlustleistungswerte für Lösungsflexibilität Generatoranwendung

VULASTIK XT

DESIGN VARIANTS DESIGNVARIANTEN



A Element

The VULASTIK XT are available in six different elastomer stiffnesses and are used in two different designs. High elastomer and narrow elastomer.

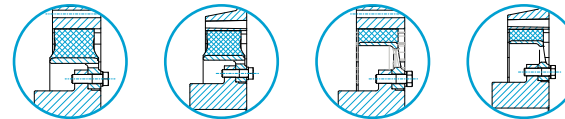

Element

Die VULASTIK XT sind in sechs verschiedenen Elastomer-Steifigkeiten erhältlich und sind in zwei verschiedenen Designs verfügbar. Hohes Elastomer und schmales Elastomer.

B Hub

Three hub connections are available. Internal hubs for plug-in mounting, unvulcanised taperlock hubs and external hubs for radial mounting.

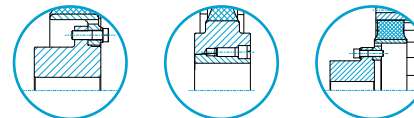

Nabe

Es stehen drei Nabenanschlüsse zur Verfügung. Innenliegende Naben zur steckbaren Montage, anvulkanisierte Taperlock-Naben und außenliegende Naben zur radialen Montage.

C Housing

The housings of the VULASTIK XT are made of lightweight aluminum and for some versions tapered to prevent collisions in certain installation situations.

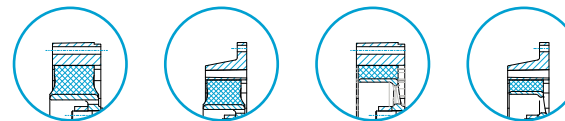

Mantel

Die Mäntel der VULASTIK XT sind in Leichtbauweise aus Aluminium gefertigt und für einige Ausführungen konisch ausgeführt, um Kollisionen in bestimmten Einbausituationen zu verhindern.



In order to make the selection of the necessary coupling as easy as possible, below is shown step by step how to understand the VULKAN nomenclature.

Um die Auswahl der notwendigen Kupplung möglichst leicht zu gestalten, ist unten schrittweise dargestellt wie die VULKAN-Nomenklatur zu verstehen ist.

1. Product family	→	2. Size code	→	3. Element stiffness	→	4. Series	→	5. Flywheel SAE	
VULASTIK XT without marine classification ohne Marine Klassifikation		Determination of nominal torque T_N and selection of an appropriate coupling. Ermittlung des Antriebsdrehmoments T_N .		Selection of needed stiffness. Auswahl der benötigten Steifigkeit.		Selection of series regarding the given application. Auswahl der Baureihe bezüglich der Einbausituation.		SAE selection. SAE Auswahl.	
VULASTIK L with marine classification mit Marine Klassifikation		Example Beispiel: 8 kNm $T_N = (P_N * 9,55) / n$		Example Beispiel: Size/Größe 3013 = 30 kNm/rad		Example Beispiel: 2800 Hub / Shaft / axial pluggable 2804 Hub / Bush / Shaft / axial pluggable 2810 Hub / Shaft / radial mountable 2800 Nabe / Welle / axial steckbar 2804 Nabe / Buchse / Welle / axial steckbar 2810 Nabe / Welle / radial montierbar		Example Beispiel: 14" / 18"	
		↓		↓		↓		↓	
		Performance data Leistungsdaten	Page / Seite	Performance data Leistungsdaten	Page / Seite	Summary of series Baureihenübersicht	Page / Seite	Geometric data Geometrische Daten	Page / Seite
		22		22		20		25	

VULASTIK XT



EXPLANATIONS OF THE PRODUCT CODE ERLÄUTERUNGEN DES PRODUKTCODES

All VULKAN Couplings products are identified by a product code. This code consists of several parameters and it enables the clear identification of all products.

Alle VULKAN Couplings Produkte sind mit einem Produktcode gekennzeichnet. Dieser Code setzt sich aus verschiedenen Parameter-Angaben zusammen und ermöglicht es, unsere Produkte eindeutig zu identifizieren.

Product Code Example VULASTIK XT Y 1913

We have decoded here the product code of a VULASTIK L (Y 1913), Size 19, 1 row, Element stiffness 3, Series 2800, Flywheel connection SAE 14", natural rubber.

Produktcode Beispiel VULASTIK XT Y 1913

Hier haben wir den Code am Beispiel einer VULASTIK L (Y 1913), Größe 19, 1-reihig, Elementsteifigkeit 3, Baureihe 2800, SAE-Schwungradanschluss 14", Gummi entschlüsselt dargestellt.

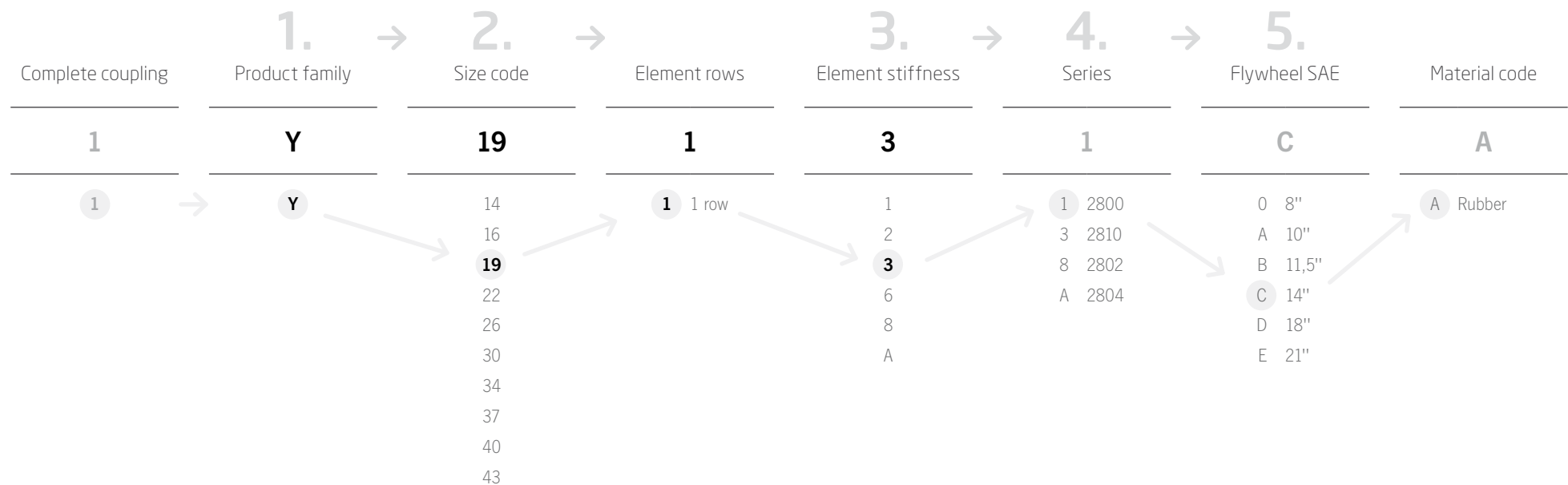



If sufficient, VULKAN recommends an approximate calculation with so-called Service-Factors allowing a rough calculation based on empirical values for the nominal torque. For periodic excitations the vibratory torque has to be considered additionally. For a detailed coupling selection or torsional vibration calculation please contact www.vulkan.com.

Permissible Values

It has to be assured, that under steady-state condition, permissible coupling values like torque, displacement or rotational speeds are not exceeded by its corresponding system torque, displacement or rotational speed.

Selection of the correct coupling size with the aid of the nominal torque

For the rough selection of the coupling VULKAN recommends to consider the service factor S_b and the temperature factor S_t . For this purpose, the nominal torque T_N at the coupling is to be subjected to the correction factors and compare it with the maximum permissible nominal torque T_{KNmax} . In case the coupling is installed in a system with periodic torque excitation, e.g. with combustion engine, VULKAN recommends confirming the selection by means of torsional vibration calculation. Furthermore, during the The permissible speed and misalignment must also be taken into account when making the selection.

$$T_{KNmax} \geq T_N \cdot S_b \cdot S_t$$

Sofern möglich empfiehlt VULKAN eine vereinfachte Auslegung mit sogenannten Betriebsfaktoren, die eine Referenzauslegung der Kupplung über das Nenndrehmoment ermöglichen. Für periodische Anregungen muss zusätzlich das Wechseldrehmoment berücksichtigt werden. Für eine detaillierte Auslegung und Drehschwingungsberechnung wenden Sie sich an www.vulkan.com.

Zulässigkeitswerte

Im stationären Betrieb muss jederzeit gewährleistet werden, dass die zulässigen Kupplungsdrehmomente, die zulässigen Verlagerungen und die zulässige Drehzahl nicht durch anlagenseitige Drehmomente, Verlagerungen oder die Drehzahl überschritten werden.

Auswahl der richtigen Kupplungsgröße unter Zuhilfenahme des Nenndrehmoments

Für die überschlägige Auswahl der Kupplung empfiehlt VULKAN die Berücksichtigung des Betriebsfaktors S_b und des Temperaturfaktors S_t . Hierzu ist das Nenndrehmoment T_N an der Kupplung mit den Korrekturfaktoren zu beaufschlagen und mit dem maximal zulässigen Nenndrehmoment T_{KNmax} zu vergleichen. Für den Fall, dass die Kupplung in einer Anlage mit periodischer Drehmomentanregung verbaut wird, z.B. mit Verbrennungsmotor, empfiehlt VULKAN die Bestätigung der Auswahl mittels Drehschwingungsberechnung. Des Weiteren sind bei der Auswahl die zulässige Drehzahl und Verlagerung zu berücksichtigen.



Selection of the service factor

The service factor S_b essentially takes into account the non-uniformity of the driving and driven machine serves for the approximate selection of the coupling. Other operating factors can be selected in consultation with VULKAN.

S_b

	Electric Motors, Hydraulic Motors, Gas and Steam Turbines Elektromotormotor, Dampf- und Gasturbine, Hydraulikmotor	Combustion Engine Verbrennungsmotor
Genset, Fan, Blower, Centrifugal Pump Generator, Lüfter, Kreiselpumpe	1,10	1,40
Hydraulic Pumps, Mixer Hydraulikpumpe, Mischer	1,35	1,65
Mill, Piston Compressors, Shredders Mühle, Kolbenkompressor, Häcksler	1,60	1,90
Crucher, Mills Brecher, Fräsen	1,85	2,15

Auswahl des Betriebsfaktors

Der Betriebsfaktor S_b berücksichtigt im Wesentlichen die ungleichförmige Belastung der An- und Abtriebsmaschine und dient zur überschlägigen Auswahl der Kupplung. In Absprache mit VULKAN können andere Betriebsfaktoren gewählt werden.

Selection of the temperature factor

The coupling can be used up to a maximum temperature of 90 °C at the coupling. High temperatures require a reduction of the maximum nominal torque of the coupling by the temperature factor S_t .

S_t

Ambient Temperature at Coupling Temperatur an der Kupplung	50 °C	60 °C	70 °C	80 °C	90 °C
Temperature Factor S_t Temperaturfaktor S_t	1,00	1,20	1,40	1,60	1,80

Auswahl des Temperaturfaktors

Die Kupplung kann bis zu einer Temperatur von maximal 90 °C an der Kupplung eingesetzt werden. Hohe Temperaturen machen eine Reduktion des maximalen Nenndrehmoments der Kupplung um den Temperaturfaktor S_t notwendig.



Maximal Nominal Torque

The maximum nominal torque T_{KNmax} is the highest nominal torque that can be permanently transmitted in steady state operation, taking into account the operating and temperature factors (S_b and S_t). In addition, T_{KNmax} must not be exceeded by the sum of the transmitted mean torque T_M and the alternating torque T_W corrected by the temperature factor S_t .

$$T_{KNmax} > (T_M + T_W) \cdot S_t$$

Maximum Torque

The maximum torque T_{Kmax} is used to evaluate torque peaks occurring for a short time. The tolerable number of load cycles is cumulatively limited to 1,000 oscillation cycles. Other maximum torques or load cycles are available on request. T_{Kmax} primarily refers to the fatigue strength of the elastic element. Customer connections, such as hubs, taper bushings or flange connections may require a correction of the maximum torque.

Vibratory Torque

The permissible alternating torque T_{KW} is used to assess the dynamic torque component in stationary operation. In particular for systems with periodic torque excitation, such as combustion engines, attention must be paid to permissibility. The permissible alternating torque T_{KW} may be exceeded, insofar as the sum of the transmitted mean torque T_M and the alternating torque T_W corrected by the temperature factor S_t does not exceed the maximum nominal torque T_{KNmax} . In this connection it must also be ensured that the permissible power loss P_{Kvtu} is not exceeded.

Displacement Values

Alignment and operational misalignments can be tolerated in angular and radial direction due to the resilience of the elastic element. The values given in the table for the permissible angular displacement ΔK_w and the permissible radial displacement ΔK_r are independent of temperature and rotational speed and are therefore permanently permissible.

Damping

The proportional damping ψ is a measure of the coupling's ability to limit oscillation deflections or to shorten deceleration processes. This is of particular interest in the case of unsteady vibration processes and near-resonant operation. The proportional damping removes vibration energy from the system by vibration energy by converting it into heat. The proportional damping is subject to the usual damping tolerances for elastomers.

Maximales Nenndrehmoment

Das maximale Nenndrehmoment T_{KNmax} ist unter Berücksichtigung von Betriebs- und Temperaturfaktor (S_b und S_t) das höchste nominelle Drehmoment, das im stationären Betrieb dauerhaft übertragen werden kann. Darüber hinaus darf T_{KNmax} durch die Summe des übertragenem mittleren Drehmoments T_M und des Wechseldrehmoments T_W korrigiert um den Temperaturfaktor S_t nicht überschritten werden.

Maximaldrehmoment

Das Maximaldrehmoment T_{Kmax} dient zur Beurteilung von kurzzeitig auftretenden Drehmomentspitzen. Die ertragbare Lastwechselzahl ist kumuliert begrenzt auf 1.000 Schwingungszyklen. Andere Maximaldrehmomente bzw. ertragbare Lastwechselzahlen sind auf Anfrage verfügbar. T_{Kmax} bezieht sich in erster Linie auf die Ermüdungsfestigkeit des elastischen Elementes. Kundenanschlüsse wie bspw. Naben, Spannbuchsen oder Flanschverbindungen können eine Korrektur des Maximaldrehmoments notwendig machen.

Wechseldrehmoment

Das zulässige Wechseldrehmoment T_{KW} dient zur Beurteilung des dynamischen Drehmomentanteils im stationären Betrieb. Insbesondere bei Anlagen mit periodischer Drehmomentanregung, wie bspw. von Verbrennungsmotoren, ist auf Zulässigkeit zu achten. Das zulässige Wechseldrehmoment T_{KW} darf überschritten werden, insofern die Summe aus übertragenem mittleren Drehmoment T_M und Wechseldrehmoment T_W korrigiert um den Temperaturfaktor S_t das maximale Nenndrehmoment T_{KNmax} nicht überschreitet. In diesem Zusammenhang ist zusätzlich sicherzustellen, dass die zulässige Verlustleistung P_{Kvtu} nicht überschritten wird.

Verlagerungswerte

Ausricht- und betriebsbedingte Verlagerungen können in winkliger und radialer Richtung aufgrund der Nachgiebigkeit des elastischen Elements toleriert werden. Die angegebenen Tabellenwerte der zulässigen winkligen Verlagerung ΔK_w und der zulässigen radialen Verlagerung ΔK_r sind unabhängig von Temperatur sowie Drehzahl und daher dauerhaft zulässig

Dämpfung

Die verhältnismäßige Dämpfung ψ ist ein Maß für das Vermögen der Kupplung, Schwingungsauslässe zu begrenzen bzw. Ausschwingvorgänge zu verkürzen. Dies ist insbesondere bei instationären Schwingungsvorgängen und dem resonanznahen Betrieb von Interesse. Die verhältnismäßige Dämpfung entzieht dem System Schwingungsenergie durch die Umwandlung in Wärme. Die verhältnismäßige Dämpfung unterliegt üblichen Dämpfungstoleranzen für Elastomere.



Power Loss

The permissible power loss P_{KVM30} is a practice-oriented characteristic value for the internal thermal load at periodic torsional vibration load of the coupling element. Depending on the operating condition and the ambient temperature, the correction factors S_{OP} and S_{TU} are to be applied. Experience has shown that the operating condition factor S_{OP} should be set to 1.0 for the normally time-limited misfire operation of internal combustion engines. For all other operating conditions or applications, the operating condition factor is 0.5. Further information on request.

Torsional Stiffness

The dynamic torsional spring stiffness C_{Tdyn} is primarily used for ideal torsional vibration tuning of the input and output machine and, if selected correctly, guarantees low-vibration operation. Therefore, it is recommended torsional vibration calculation for systems with periodic torsional excitation to determine the ideal torsional spring stiffness. The values in the tables refers to sensful selected reference conditions for average torque, temperature an oscillation frequency. The torsional stiffness is subject to usual stiffness tolerances for elastomers.

Maximale Drehzahl

n_{Kmax} is the maximum permissible operating speed of the coupling.

P_{KVTU}

$$P_{KVTU} = S_{OP} \cdot S_{TU} \cdot P_{KVM30}$$

S_{TU}

Ambient Temperature Umgebungstemperatur				
50 °C	60 °C	70 °C	80 °C	90 °C
0,750	0,625	0,500	0,375	0,250

$$S_{tu} = (110 - T_u) / 80$$

Verlustleistung

Die zulässige Verlustleistung P_{KVM30} ist ein praxisgerechter Kennwert für die innere Wärmelast bei periodischer Drehschwingungsbelastung des Kupplungselementes. Der Katalogwert P_{KVM30} ist unter Berücksichtigung von Betriebszustand S_{OP} sowie Umgebungstemperatur S_{TU} zu reduzieren. Der Betriebszustandsfaktor S_{OP} ist erfahrungsgemäß für den in der Regel zeitlich begrenzten Zündaussetzerbetrieb von Verbrennungsmotoren mit 1.0 anzusetzen. Für alle anderen Betriebszustände bzw. Anwendungen beträgt der Betriebszustandsfaktor 0.5. Weitere Informationen auf Anfrage.

Drehfedersteifigkeit

Die dynamische Drehfedersteifigkeit C_{Tdyn} dient in erster Linie zur idealen Drehschwingungsabstimmung von An- und Abtriebsmaschine und ist bei richtiger Wahl Garant für einen schwingungsarmen Betrieb. Daher empfiehlt sich für Anlagen mit periodischer Drehmomentanregung eine Drehschwingungsberechnung zur Ermittlung der idealen Drehfedersteifigkeit. Die Tabellenwerte C_{Tdyn} beziehen sich auf sinnvoll gewählte Referenzbedingungen für mittleres Drehmoment, Wechseldrehmoment, Temperatur und Schwingfrequenz. Die Drehsteifigkeit unterliegt üblichen Steifigkeitstoleranzen für Elastomere.

Maximale Drehzahl

n_{Kmax} ist die maximal zulässige Betriebsdrehzahl der Kupplung.



Hub length

The installation dimensions L_1 and L_2 describe the standard and can be shorten depending on the installation. The adjustment of the hub length is depending on the nominal torque T_N of the application. For further information, please contact your local VULKAN representative or for calculation of a keyway connections please visit the VULKAN Engineering portal on www.vulkan.com.

Masses and mass moments of inertia

All masses, focal points and mass moments of inertia refer to min. hub diameter at max. hub length.

Taper bush design

The suitable clamping bushes are not included in the VULKAN scope of delivery. The manufacturer's performance specifications must be observed.

Nabenlänge

L_1 und L_2 beschreiben Standardsituationen und können im Anwendungsfall angepasst werden. Die Auslegung der Nabenlänge erfolgt in Abhängigkeit des Anlagemomentes T_N und muss anwendungsbezogen berechnet werden. Kontaktieren Sie hierfür die VULKAN Vertretung in Ihrer Nähe oder besuchen Sie für Naben mit Passfederverbindung das VULKAN Engineering Portal auf unserer Homepage www.vulkan.com.

Massen, Schwerpunkte und Massenträgheitsmomente

Alle Massen, Schwerpunkte und Massenträgheitsmomente beziehen sich auf min. Nabendurchmesser bei max. Nabenlänge.

Spannbuchsenausführungen

Die passenden Spannbuchsen sind nicht im Lieferumfang von VULKAN enthalten. Die Leistungsangaben der Hersteller sind zu beachten.

Further information about applications in the field of marine and stationary power generation as well as about applications involving classification societies, can be found in the VULASTIK L catalogue as well as in the explanation technical data.

Informationen zu spezifischen Anwendungen im Bereich Marine und stationäre Stromerzeugung, sowie zu Anwendungen, die die Genehmigung einer Klassifikationsgesellschaft erfordern, finden Sie ergänzend im VULASTIK L Katalog und in den Erläuterungen der technischen Daten.

VULASTIK L

www.vulkan.com/en-us/couplings/products/highly-flexible-couplings/vulastik-l



VULASTIK L

www.vulkan.com/de-de/couplings/produkte/hochelastische-kupplungen/vulastik-l

EXPLANATION OF TECHNICAL DATA

www.vulkan.com/en-us/couplings/downloads-videos/explanation-of-technical-data



ERLÄUTERUNG DER TECHNISCHEN DATEN

www.vulkan.com/de-de/couplings/downloads-videos/erlaeuterung-der-technischen-daten

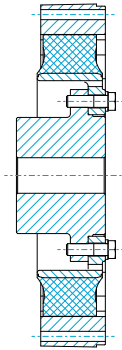

Series 2800

For connecting an SAE flywheel J620 to a shaft.

Design for bell housing installations. Replacement of elements by moving the adjacent machinery.

Zur Verbindung eines SAE-Schwungrades J620 mit einer Welle.

Ausführung für Glockeneinbauten. Elementenwechsel durch Verschieben der verbundenen Maschinen.

Dimension Group Baugruppe

Y1410 – Y4310

Nominal Torque Nenndrehmoment

0,56 – 38,60 kNm

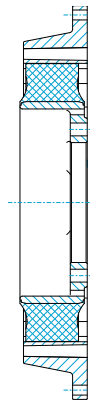

Series 2802

For connecting an SAE flywheel J620 with a hub or flange.

Design for bell housing installations. Replacement of elements by moving the adjacent machinery. Without hub.

Zur Verbindung eines SAE-Schwungrades J620 mit einer Nabe oder einem Flansch.

Ausführung für Glockeneinbauten. Elementenwechsel durch Verschieben der verbundenen Maschinen. Ohne Nabe.

Dimension Group Baugruppe

Y1410 – Y4310

Nominal Torque Nenndrehmoment

0,56 – 38,60 kNm

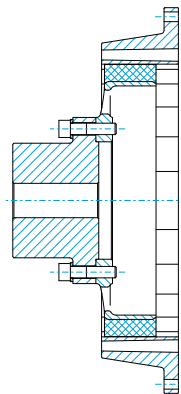

Series 2804

For connecting an SAE flywheel J620 to a shaft.

Design for bell housing installations with clamping connection. Replacement of elements by moving the adjacent machinery. The performance data of the bushes used must be observed.

Zur Verbindung eines SAE-Schwungrades J620 mit einer Welle.

Ausführung für Glockeneinbauten. Befestigung mit Klemmnabe. Elementenwechsel durch Verschieben der verbundenen Maschinen. Die Leistungsdaten der verwendeten Buchsen sind zu beachten.

Dimension Group Baugruppe

Y1410 – Y3410

Nominal Torque Nenndrehmoment

0,56 – 11,20 kNm

Series 2810

For connecting an SAE flywheel J620 to a shaft.

Replacement of elements without moving the adjacent machinery. The elements can be removed vertically by moving the flanged casing.

Zur Verbindung eines SAE-Schwungrades J620 mit einer Welle.

Elementenwechsel ohne Verschieben der verbundenen Maschinen. Durch Zurückziehen des Flanschmantels können die Elemente senkrecht ausgebaut werden.

Dimension Group Baugruppe

Y1410 – Y4310

Nominal Torque Nenndrehmoment

0,56 – 38,60 kNm

VULASTIK XT



PERFORMANCE DATA LEISTUNGSDATEN



Size code	Element rows	Element stiffness	Dimension group	Permissible Values							Spring Characteristics	
				T_{KNmax}	T_{Kmax}	T_{KW}	P_{KVH30}	n_{Kmax}	ΔK_r	ΔK_w	C_{Tdyn}	Ψ
				Max. Nom. Torque	Max. Torque	Vibratory Torque	Power Loss	Max. Rot. Speed	Radial Coupling Displacement	Angular Coupling Displacement	Dyn. Torsional Stiffness	Relative Damping
				[kNm]	[kNm]	[kNm]	[kW]	[min ⁻¹]	[mm]	[°]	[kNm/rad]	[-]
▶ 14 – 22												
▶ 26 – 34												
▶ 37 – 43												
14	1	1	Y1410	0,56	1,20	0,16	0,460	5300	1,0	0,5	2,0	1,00
14	1	2	Y1410	0,70	1,50	0,20	0,460	5300	1,0	0,5	2,5	1,13
14	1	3	Y1410	0,70	1,50	0,20	0,420	5300	1,0	0,5	5,0	1,13
16	1	1	Y1610	0,88	1,89	0,25	0,660	4100	1,0	0,5	2,5	1,00
16	1	2	Y1610	1,12	2,40	0,32	0,660	4100	1,0	0,5	4,5	1,13
16	1	3	Y1610	1,12	2,40	0,32	0,580	4100	1,0	0,5	8,5	1,13
19	1	1	Y1910	1,40	3,00	0,40	0,720	3600	1,0	0,5	4,5	1,00
19	1	2	Y1910	1,75	3,75	0,50	0,720	3600	1,0	0,5	7,5	1,13
19	1	3	Y1910	1,75	3,75	0,50	0,660	3600	1,0	0,5	14,0	1,13
22	1	1	Y2210	2,24	4,80	0,64	0,860	3200	1,5	0,5	7,0	1,00
22	1	2	Y2210	2,80	6,00	0,80	0,860	3200	1,0	0,5	12,0	1,13
22	1	3	Y2210	2,80	6,00	0,80	0,920	3200	1,0	0,5	21,0	1,13
22	1	6	Y2210	2,80	6,00	0,80	0,920	3200	1,0	0,5	36,0	1,13
22	1	A	Y2210	2,80	6,00	0,80	0,920	3200	1,0	0,5	72,0	1,13

Please consider the explanations of technical data on page 15 ff. Bitte beachten Sie die Erläuterung der technischen Daten ab Seite 15.

VULASTIK XT



PERFORMANCE DATA LEISTUNGSDATEN

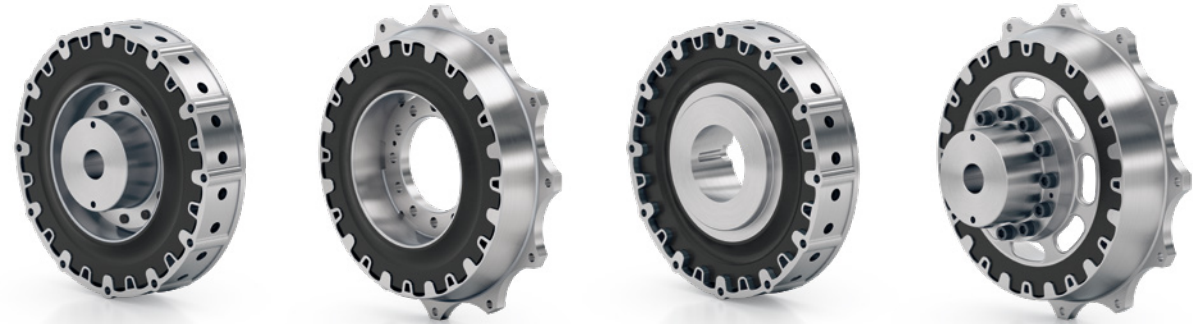

Size code	Element rows	Element stiffness	Dimension group	Permissible Values							Spring Characteristics	
				T_{KNmax}	T_{Kmax}	T_{KW}	P_{KVH30}	n_{Kmax}	ΔK_r	ΔK_w	C_{tdyn}	Ψ
				Max. Nom. Torque	Max. Torque	Vibratory Torque	Power Loss	Max. Rot. Speed	Radial Coupling Displacement	Angular Coupling Displacement	Dyn. Torsional Stiffness	Relative Damping
				[kNm]	[kNm]	[kNm]	[kW]	[min ⁻¹]	[mm]	[°]	[kNm/rad]	[-]
▶ 14 - 22												
▶ 26 - 34												
▶ 37 - 43												
26	1	1	Y2610	3,50	7,50	1,00	0,980	2,700	1,5	0,5	11,5	1,00
26	1	2	Y2610	4,40	9,45	1,25	0,980	2,700	1,0	0,5	19,5	1,13
26	1	3	Y2610	4,40	9,45	1,25	0,980	2,700	1,0	0,5	36,0	1,13
26	1	6	Y2610	4,40	9,45	1,25	0,820	2,700	1,0	0,3	58,0	0,80
26	1	8	Y2610	4,40	9,45	1,25	0,820	2,700	1,0	0,3	80,0	0,90
26	1	A	Y2610	4,40	9,45	1,25	0,820	2,700	1,0	0,3	116,0	1,00
30	1	1	Y3010	5,60	12,00	1,60	0,700	2,500	1,5	0,5	19,0	1,00
30	1	2	Y3010	7,00	15,00	2,00	0,700	2,500	1,0	0,5	30,0	1,13
30	1	3	Y3010	7,00	15,00	2,00	0,740	2,500	1,0	0,5	58,0	1,13
30	1	6	Y3010	7,00	15,00	2,00	0,900	2,500	1,0	0,3	100,0	0,80
30	1	8	Y3010	7,00	15,00	2,00	0,900	2,500	1,0	0,3	125,0	0,90
30	1	A	Y3010	7,00	15,00	2,00	0,900	2,500	1,0	0,3	181,3	1,00
34	1	1	Y3410	8,80	18,90	2,50	0,900	2,500	1,5	0,5	43,0	1,00
34	1	2	Y3410	11,20	24,00	3,20	0,900	2,500	1,0	0,5	67,0	1,13
34	1	3	Y3410	11,20	24,00	3,20	0,840	2,500	1,0	0,5	85,0	1,13
34	1	6	Y3410	11,20	24,00	3,20	1,020	2,500	1,0	0,3	150,0	0,80
34	1	8	Y3410	11,20	24,00	3,20	1,020	2,500	1,0	0,3	200,0	0,90
34	1	A	Y3410	11,20	24,00	3,20	1,020	2,500	1,0	0,3	303,0	1,00

Please consider the explanations of technical data on page 15 ff. Bitte beachten Sie die Erläuterung der technischen Daten ab Seite 15.

VULASTIK XT



PERFORMANCE DATA LEISTUNGSDATEN

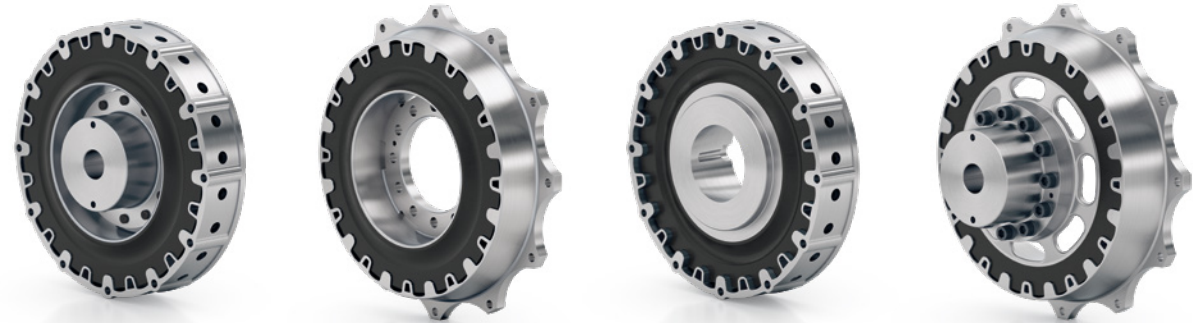

Size code	Element rows	Element stiffness	Dimension group	Permissible Values							Spring Characteristics	
				T_{KNmax}	T_{Kmax}	T_{KW}	P_{KVH30}	n_{Kmax}	ΔK_r	ΔK_w	C_{tdyn}	Ψ
				Max. Nom. Torque	Max. Torque	Vibratory Torque	Power Loss	Max. Rot. Speed	Radial Coupling Displacement	Angular Coupling Displacement	Dyn. Torsional Stiffness	Relative Damping
				[kNm]	[kNm]	[kNm]	[kW]	[min ⁻¹]	[mm]	[°]	[kNm/rad]	[-]
▶ 14 - 22												
▶ 26 - 34												
▶ 37 - 43												
37	1	1	Y3710	11,20	24,00	3,20	0,920	2500	1,5	0,5	61,0	1,00
37	1	2	Y3710	14,00	30,00	4,00	0,920	2500	1,0	0,5	94,0	1,13
37	1	3	Y3710	14,00	30,00	4,00	0,820	2500	1,0	0,5	120,0	1,13
37	1	6	Y3710	15,10	32,40	4,30	1,100	2500	1,0	0,3	230,0	0,80
37	1	8	Y3710	16,20	34,80	4,60	1,100	2500	1,0	0,3	300,0	0,90
37	1	A	Y3710	18,20	39,00	5,20	1,100	2500	1,0	0,3	380,0	1,00
40	1	1	Y4010	14,00	30,00	4,00	1,100	2500	1,5	0,5	68,0	1,00
40	1	2	Y4010	17,50	37,50	5,00	1,100	2500	1,0	0,5	105,0	1,13
40	1	3	Y4010	17,50	37,50	5,00	1,140	2500	1,0	0,5	135,0	1,13
40	1	6	Y4010	21,30	45,60	6,10	1,240	2500	1,0	0,3	290,0	0,80
40	1	8	Y4010	22,40	48,00	6,40	1,240	2500	1,0	0,3	370,0	0,90
40	1	A	Y4010	25,80	55,20	7,40	1,240	2500	1,0	0,3	470,0	1,00
43	1	1	Y4310	22,40	48,00	6,40	1,320	2500	1,5	0,5	130,0	1,00
43	1	2	Y4310	28,00	60,00	8,00	1,320	2500	1,0	0,5	190,0	1,13
43	1	3	Y4310	28,00	60,00	8,00	1,140	2500	1,0	0,5	335,0	1,13
43	1	6	Y4310	31,10	66,60	8,90	1,700	2000	1,0	0,3	450,0	0,80
43	1	8	Y4310	33,60	72,00	9,60	1,700	2000	1,0	0,3	550,0	0,90
43	1	A	Y4310	38,60	82,80	11,00	1,700	2000	1,0	0,3	700,0	1,00

Please consider the explanations of technical data on page 15 ff. Bitte beachten Sie die Erläuterung der technischen Daten ab Seite 15.



GEOMETRIC DATA GEOMETRISCHE DATEN

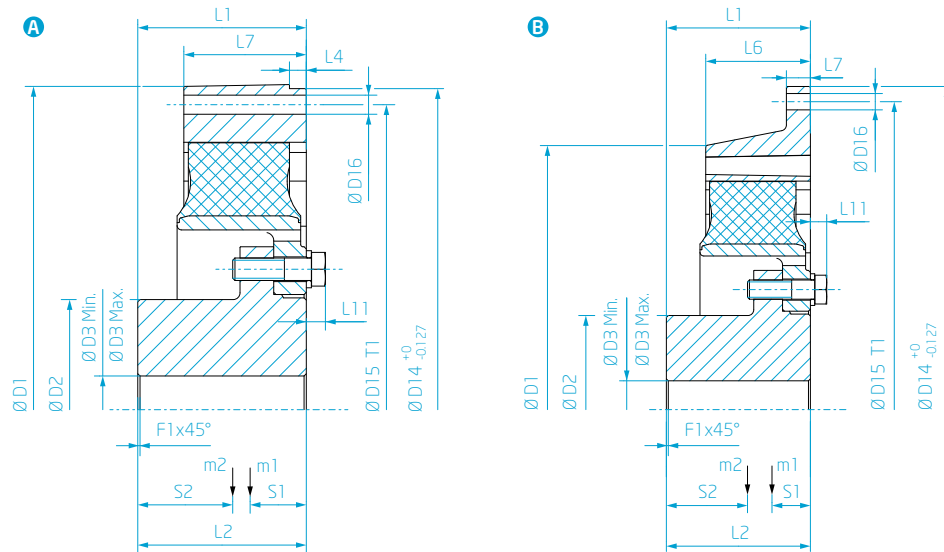

Size code	Element rows	Dimension group	Flywheel	Dimension													Mass moments of inertia		Mass		Distance to center of gravity				
				SAEJ620	D ₁	D ₂	D ₃		D ₁₄	D ₁₅	T ₁	D ₁₆	L ₁	L ₂	L ₄	L ₆	L ₇	L ₁₁	F ₁	J ₁	J ₂	m ₁	m ₂	S ₁	S ₂
▶ 14 - 22	▶ 26 - 34	▶ 37 - 43		[°]	[mm]	[mm]	[mm] Min.	[mm] Max.	[mm]	[mm]	[-] Holes	[mm]	[mm]	[mm]	[mm]	[mm]	[mm]	[mm]	[mm]	[kgm ²]	[kgm ²]	[kg]	[kg]	[mm]	[mm]
A 14	1	Y 1410	8	262,0	84,0	20,0	60,0	263,5	244,5	6	11,0	80,9	82,0	10,0	-	34,0	13,0	1,5	0,019	0,010	1,4	5,0	16,7	52,0	
B 14	1	Y 1410	10	265,0	84,0	20,0	60,0	314,4	295,3	8	11,0	73,0	82,0	-	34,0	10,0	13,0	1,5	0,033	0,010	2,1	5,0	13,9	48,7	
B 14	1	Y 1410	11½	265,0	84,0	20,0	60,0	352,4	333,4	8	11,0	106,7	105,0	-	34,0	10,0	12,8	1,5	0,050	0,010	2,6	5,9	12,2	66,7	
A 16	1	Y 1610	10	312,0	98,0	25,0	70,0	314,4	295,3	8	11,0	73,0	82,0	10,0	-	40,0	13,0	1,5	0,040	0,020	2,1	6,9	19,6	48,0	
B 16	1	Y 1610	11½	315,0	98,0	25,0	70,0	352,4	333,4	8	11,0	106,7	105,0	-	40,0	10,0	12,8	1,5	0,060	0,020	2,9	8,1	17,5	66,6	
B 16	1	Y 1610	14	314,0	98,0	25,0	70,0	466,7	438,2	8	14,0	92,4	105,0	-	40,0	10,0	13,1	1,5	0,140	0,020	4,5	8,1	12,1	61,3	
A 19	1	Y 1910	11½	356,0	118,0	35,0	85,0	352,4	333,4	8	11,0	106,7	105,0	12,0	-	48,0	14,8	1,5	0,080	0,040	3,3	11,9	24,6	66,0	
B 19	1	Y 1910	14	356,0	118,0	35,0	85,0	466,7	438,2	8	14,0	92,4	105,0	-	48,0	12,0	15,1	1,5	0,180	0,040	5,7	11,6	17,4	60,1	
B 22	1	Y 2210	14	410,0	133,0	35,0	95,0	466,7	438,2	8	14,0	92,4	105,0	-	53,0	15,0	18,6	1,5	0,230	0,090	6,1	17,0	22,0	61,4	

Please consider the explanations of technical data on page 15 ff. Bitte beachten Sie die Erläuterung der technischen Daten ab Seite 15.



GEOMETRIC DATA GEOMETRISCHE DATEN

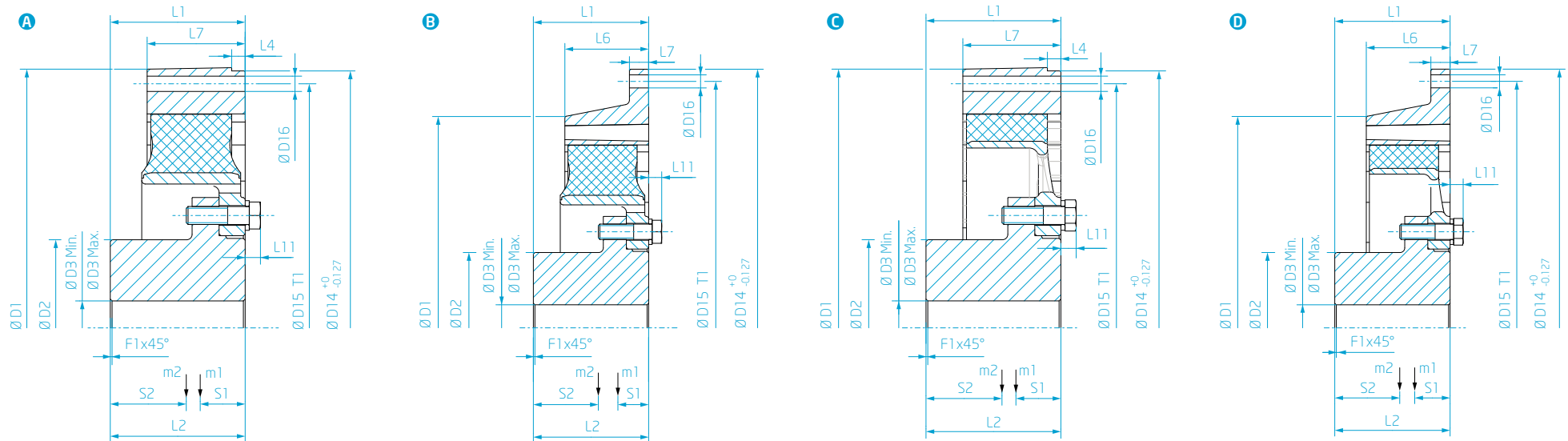

Size code	Element rows	Dimension group	Flywheel	Dimension													Mass moments of inertia		Mass		Distance to center of gravity				
			SAEJ620	D ₁	D ₂	D ₃	D ₁₄	D ₁₅	T ₁	D ₁₆	L ₁	L ₂	L ₄	L ₆	L ₇	L ₁₁	F ₁	J ₁	J ₂	m ₁	m ₂	S ₁	S ₂		
			[°]	[mm]	[mm]	[mm] Min. Max.	[mm]	[mm]	[-] Holes	[mm]	[mm]	[mm]	[mm]	[mm]	[mm]	[mm]	[mm]	[kgm ²]	[kgm ²]	[kg]	[kg]	[mm]	[mm]		
▶ 14 – 22																									
▶ 26 – 34																									
▶ 37 – 43																									
A	26	1	Y 2610	14	470,0	154,0	45,0	110,0	466,7	438,2	8	14,0	92,4	105,0	18,0	-	62,0	14,1	1,5	0,290	0,180	6,7	23,8	30,5	60,0
B	26	1	Y 2610	18	470,0	154,0	45,0	110,0	571,5	542,9	12	17,0	82,7	105,0	-	62,0	18,0	22,3	1,5	0,600	0,180	11,4	23,7	23,8	55,2
C	26	1	Y 2610	14	470,0	154,0	45,0	110,0	466,7	438,2	8	14,0	92,4	105,0	18,0	-	62,0	14,1	1,5	0,260	0,260	5,6	25,0	30,4	61,3
D	26	1	Y 2610	18	470,0	154,0	45,0	110,0	571,5	542,9	12	17,0	82,7	105,0	-	62,0	18,0	22,3	1,5	0,570	0,260	10,3	24,9	22,9	56,3
A	30	1	Y 3010	14	470,0	168,0	50,0	120,0	466,7	438,2	8	14,0	92,4	105,0	20,0	-	80,0	20,1	2,0	0,350	0,250	8,1	28,5	39,3	58,1
B	30	1	Y 3010	18	470,0	168,0	50,0	120,0	571,5	542,9	12	17,0	135,0	135,0	-	80,0	20,0	20,5	2,0	0,730	0,260	14,2	33,1	31,3	84,4
C	30	1	Y 3010	14	470,0	168,0	50,0	120,0	466,7	438,2	8	14,0	92,4	105,0	20,0	-	80,0	20,1	2,0	0,300	0,320	6,5	28,3	39,1	59,9
D	30	1	Y 3010	18	470,0	168,0	50,0	120,0	571,5	542,9	12	17,0	135,0	135,0	-	80,0	20,0	20,5	2,0	0,680	0,340	12,5	33,0	30,1	85,9
A	34	1	Y 3410	18	580,0	185,0	60,0	130,0	571,5	542,9	12	17,0	150,0	150,0	15,0	-	109,0	17,0	2,0	1,080	0,810	16,5	59,8	57,6	90,9
B	34	1	Y 3410	21	550,0	185,0	60,0	130,0	673,1	641,4	12	17,0	150,0	150,0	-	109,0	25,0	17,0	2,0	1,500	0,810	21,3	59,8	48,3	90,9
C	34	1	Y 3410	18	580,0	185,0	60,0	130,0	571,5	542,9	12	17,0	150,0	150,0	15,0	-	109,0	17,0	2,0	1,010	0,840	14,8	57,4	56,5	92,1
D	34	1	Y 3410	21	550,0	185,0	60,0	130,0	673,1	641,4	12	17,0	150,0	150,0	-	109,0	25,0	17,0	2,0	1,430	0,840	19,6	57,4	46,7	92,1

Please consider the explanations of technical data on page 15 ff. Bitte beachten Sie die Erläuterung der technischen Daten ab Seite 15.



GEOMETRIC DATA GEOMETRISCHE DATEN

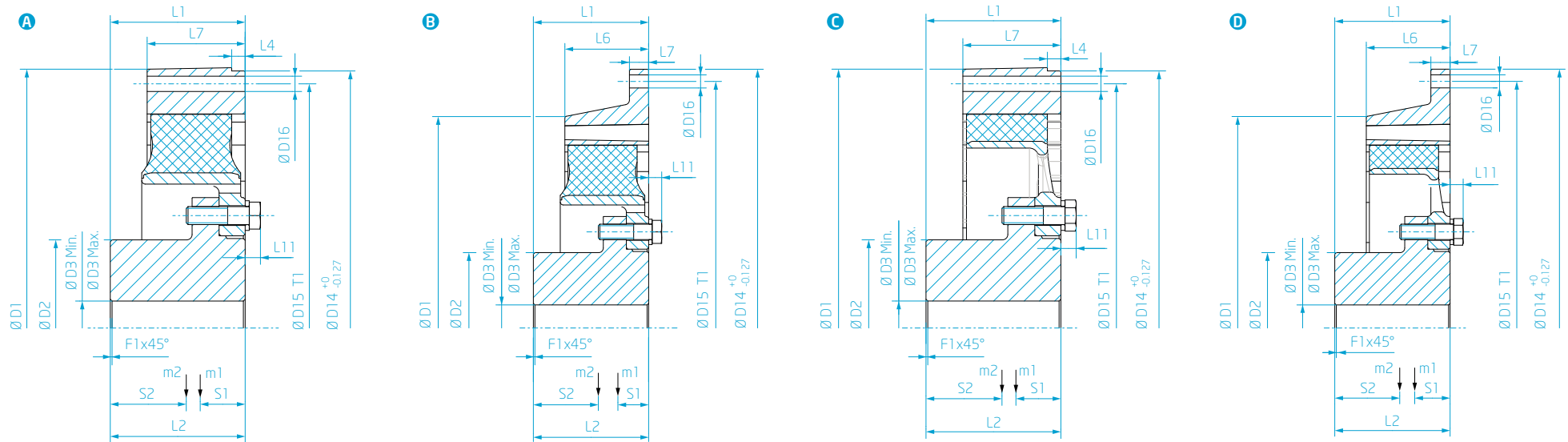

Size code	Element rows	Dimension group	Flywheel	Dimension													Mass moments of inertia		Mass		Distance to center of gravity			
				SAEJ620	D ₁	D ₂	D ₃	D ₁₄	D ₁₅	T ₁	D ₁₆	L ₁	L ₂	L ₄	L ₆	L ₇	L ₁₁	F ₁	J ₁	J ₂	m ₁	m ₂	S ₁	S ₂
▶ 14 - 22				[°]	[mm]	[mm]	[mm]	[mm]	[mm]	[mm]	[mm]	[mm]	[mm]	[mm]	[mm]	[mm]	[mm]	[mm]	[kgm ²]	[kgm ²]	[kg]	[kg]	[mm]	[mm]
▶ 26 - 34							Min.	Max.																
▶ 37 - 43																								
A 37	1	Y 3710	18	580,0	196,0	60,0	140,0	571,5	542,9	12	17,0	150,0	150,0	15,0	-	109,0	17,0	2,0	1,150	0,870	178	61,2	55,7	92,9
B 37	1	Y 3710	21	550,0	196,0	60,0	140,0	673,1	641,4	12	17,0	150,0	150,0	-	109,0	25,0	17,0	2,0	1,580	0,870	228	61,2	47,6	92,9
C 37	1	Y 3710	18	580,0	196,0	60,0	140,0	571,5	542,9	12	17,0	150,0	150,0	15,0	-	109,0	17,0	2,0	1,060	0,840	15,7	56,4	55,1	93,9
D 37	1	Y 3710	21	550,0	196,0	60,0	140,0	673,1	641,4	12	17,0	150,0	150,0	-	109,0	25,0	17,0	2,0	1,500	0,840	20,7	56,4	46,3	93,9
A 40	1	Y 4010	21	680,0	205,0	70,0	145,0	673,1	641,4	12	17,0	175,0	160,0	15,0	-	130,0	18,5	2,0	2,510	1,670	278	86,9	68,3	104,8
C 40	1	Y 4010	21	680,0	205,0	70,0	145,0	673,1	641,4	12	17,0	175,0	160,0	15,0	-	130,0	18,5	2,0	2,400	1,690	25,7	81,9	67,6	106,2
A 43	1	Y 4310	21	680,0	238,0	70,0	170,0	673,1	641,4	12	17,0	195,0	190,0	15,0	-	170,0	19,5	2,0	3,470	2,380	38,9	118,0	83,1	116,1
C 43	1	Y 4310	21	680,0	238,0	70,0	170,0	673,1	641,4	12	17,0	195,0	190,0	15,0	-	170,0	19,5	2,0	3,280	2,200	35,4	104,9	83,0	118,7

Please consider the explanations of technical data on page 15 ff. Bitte beachten Sie die Erläuterung der technischen Daten ab Seite 15.



GEOMETRIC DATA GEOMETRISCHE DATEN

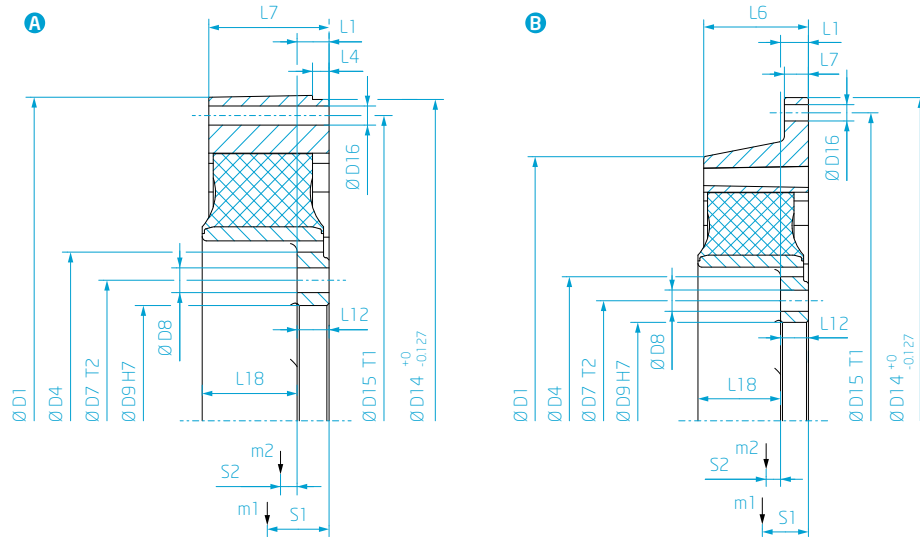

Size code	Element rows	Dimension group	Flywheel	Dimension														Mass moments of inertia		Mass		Distance to center of gravity				
				SAEJ620	D ₁	D ₄	D ₇	T ₂	D ₈	D ₉	D ₁₄	D ₁₅	T ₁	D ₁₆	L ₁	L ₄	L ₆	L ₇	L ₁₂	L ₁₈	J ₁	J ₂	m ₁	m ₂	S ₁	S ₂
▶ 14 – 22				[°]	[mm]	[mm]	[mm]	[–] Holes	[mm]	[mm]	[mm]	[mm]	[–] Holes	[mm]	[mm]	[mm]	[mm]	[mm]	[mm]	[mm]	[kgm ²]	[kgm ²]	[kg]	[kg]	[mm]	[mm]
▶ 26 – 34																										
▶ 37 – 43																										
A 14	1	Y 1410	8	262,0	118,0	102,0	8	11,0	82,0	263,5	244,5	6	11,0	9,0	10,0	-	34,0	9,0	25,0	0,019	0,005	1,4	1,2	16,7	3,4	
B 14	1	Y 1410	10	265,0	118,0	102,0	8	11,0	82,0	314,4	295,3	8	11,0	9,0	-	34,0	10,0	9,0	25,0	0,033	0,005	2,1	1,2	13,9	3,4	
B 14	1	Y 1410	11½	265,0	118,0	102,0	8	11,0	82,0	352,4	333,4	8	11,0	9,0	-	34,0	10,0	9,0	25,0	0,047	0,005	2,6	1,2	12,2	3,4	
A 16	1	Y 1610	10	312,0	136,0	115,0	10	11,0	95,0	314,4	295,3	8	11,0	11,0	10,0	-	40,0	11,0	29,0	0,040	0,010	2,1	1,9	19,6	4,0	
B 16	1	Y 1610	11½	315,0	136,0	115,0	10	11,0	95,0	352,4	333,4	8	11,0	11,2	-	40,0	10,0	11,0	29,0	0,060	0,010	2,9	1,9	17,5	4,0	
B 16	1	Y 1610	14	315,0	136,0	115,0	10	11,0	95,0	466,7	438,2	8	14,0	11,2	-	40,0	10,0	11,0	29,0	0,140	0,010	4,5	1,9	12,1	4,0	
A 19	1	Y 1910	11½	356,0	160,0	135,0	10	14,0	110,0	352,4	333,4	8	11,0	14,7	12,0	-	48,0	13,0	33,0	0,080	0,020	3,3	2,9	24,6	3,5	
B 19	1	Y 1910	14	356,0	160,0	135,0	10	14,0	110,0	466,7	438,2	8	14,0	14,4	-	48,0	12,0	13,0	33,0	0,180	0,020	5,7	2,9	17,4	3,5	
B 22	1	Y 2210	14	410,0	190,0	160,0	10	16,0	132,0	466,7	438,2	8	14,0	14,9	-	53,0	15,0	15,0	38,0	0,230	0,050	6,1	4,6	22,0	4,3	

Please consider the explanations of technical data on page 15 ff. Bitte beachten Sie die Erläuterung der technischen Daten ab Seite 15.



GEOMETRIC DATA GEOMETRISCHE DATEN

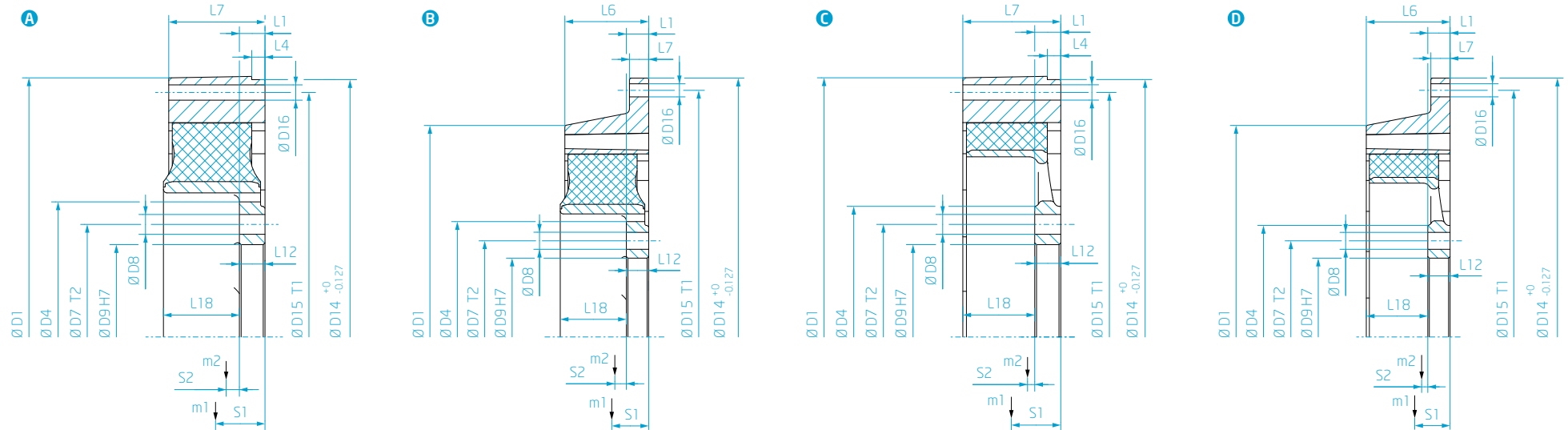

Size code	Element rows	Dimension group	Flywheel	Dimension														Mass moments of inertia		Mass		Distance to center of gravity				
			SAEJ620	D ₁	D ₄	D ₇	T ₂	D ₈	D ₉	D ₁₄	D ₁₅	T ₁	D ₁₆	L ₁	L ₄	L ₆	L ₇	L ₁₂	L ₁₈	J ₁	J ₂	m ₁	m ₂	S ₁	S ₂	
			[°]	[mm]	[mm]	[mm]	[-] Holes	[mm]	[mm]	[mm]	[mm]	[-] Holes	[mm]	[mm]	[mm]	[mm]	[mm]	[mm]	[mm]	[kgm ²]	[kgm ²]	[kg]	[kg]	[mm]	[mm]	
▶ 14 - 22																										
▶ 26 - 34																										
▶ 37 - 43																										
A	26	1	Y 2610	14	470,0	220,0	190,0	8	18,0	155,0	466,7	438,2	8	14,0	18,0	-	62,0	18,0	44,0	0,290	0,100	6,7	7,1	30,5	4,1	
B	26	1	Y 2610	18	470,0	220,0	190,0	8	18,0	155,0	571,5	542,9	12	17,0	18,7	-	62,0	18,0	18,0	44,0	0,600	0,100	11,4	7,1	23,8	4,1
C	26	1	Y 2610	14	470,0	220,0	190,0	8	18,0	155,0	466,7	438,2	8	14,0	18,4	18,0	-	62,0	18,0	44,0	0,260	0,190	5,6	8,3	30,4	1,7
D	26	1	Y 2610	18	470,0	220,0	190,0	8	18,0	155,0	571,5	542,9	12	17,0	18,7	-	62,0	18,0	18,0	44,0	0,570	0,190	10,3	8,3	22,9	1,7
A	30	1	Y 3010	14	470,0	220,0	190,0	12	18,0	160,0	466,7	438,2	8	14,0	16,4	20,0	-	80,0	22,0	70,0	0,350	0,160	8,1	10,1	39,3	13,5
B	30	1	Y 3010	18	470,0	220,0	190,0	12	18,0	160,0	571,5	542,9	12	17,0	16,0	-	80,0	20,0	22,0	70,0	0,730	0,150	14,2	10,0	31,3	13,4
C	30	1	Y 3010	14	470,0	220,0	190,0	12	18,0	160,0	466,7	438,2	8	14,0	16,4	20,0	-	80,0	22,0	64,0	0,300	0,230	6,5	9,9	39,1	8,3
D	30	1	Y 3010	18	470,0	220,0	190,0	12	18,0	160,0	571,5	542,9	12	17,0	16,0	-	80,0	20,0	22,0	64,0	0,680	0,230	12,5	9,9	30,1	8,3
A	34	1	Y 3410	18	580,0	290,0	250,0	12	22,0	205,0	571,5	542,9	12	17,0	49,0	15,0	-	109,0	49,0	60,0	1,080	0,510	16,5	22,3	57,6	3,7
B	34	1	Y 3410	21	550,0	290,0	250,0	12	22,0	205,0	673,1	641,4	12	17,0	49,0	-	109,0	25,0	49,0	60,0	1,500	0,510	21,3	22,3	48,3	3,7
C	34	1	Y 3410	18	580,0	290,0	250,0	12	22,0	205,0	571,5	542,9	12	17,0	49,0	15,0	-	109,0	49,0	60,0	1,010	0,540	14,8	19,9	56,5	8,8
D	34	1	Y 3410	21	550,0	290,0	250,0	12	22,0	205,0	673,1	641,4	12	17,0	49,0	-	109,0	25,0	49,0	60,0	1,430	0,540	19,6	19,9	46,7	8,8

Please consider the explanations of technical data on page 15 ff. Bitte beachten Sie die Erläuterung der technischen Daten ab Seite 15.



GEOMETRIC DATA GEOMETRISCHE DATEN

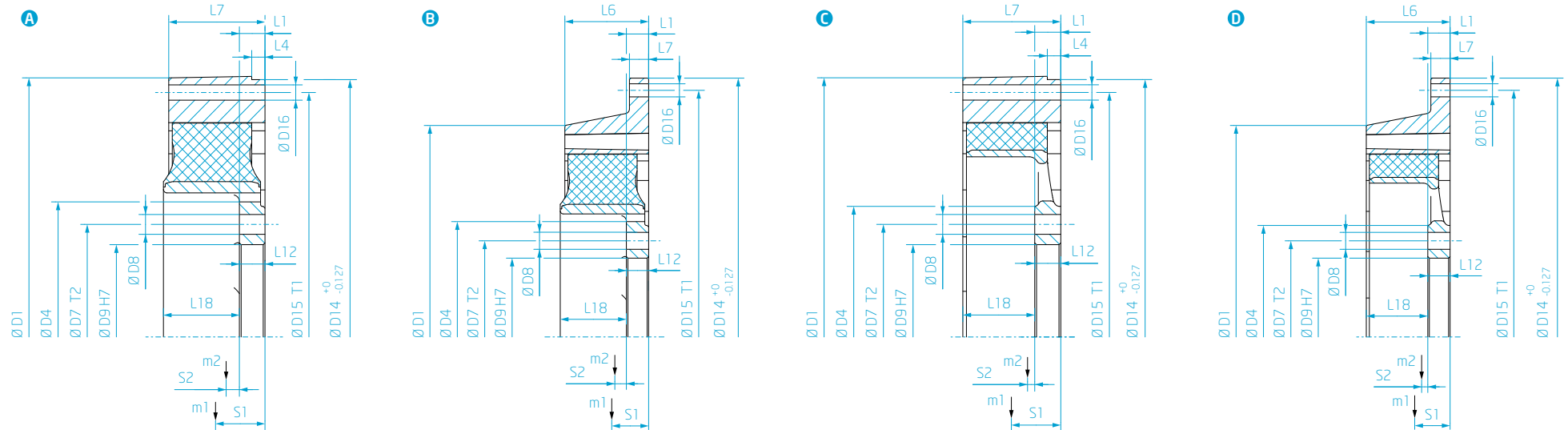

Size code	Element rows	Dimension group	Flywheel	Dimension														Mass moments of inertia		Mass		Distance to center of gravity			
			SAEJ620	D ₁	D ₄	D ₇	T ₂	D ₈	D ₉	D ₁₄	D ₁₅	T ₁	D ₁₆	L ₁	L ₄	L ₆	L ₇	L ₁₂	L ₁₈	J ₁	J ₂	m ₁	m ₂	S ₁	S ₂
			[°]	[mm]	[mm]	[mm]	[-] Holes	[mm]	[mm]	[mm]	[mm]	[-] Holes	[mm]	[mm]	[mm]	[mm]	[mm]	[mm]	[mm]	[kgm ²]	[kgm ²]	[kg]	[kg]	[mm]	[mm]
▶ 14 – 22																									
▶ 26 – 34																									
▶ 37 – 43																									
A 37	1	Y 3710	18	580,0	290,0	250,0	12	22,0	205,0	571,5	542,9	12	17,0	29,0	15,0	-	109,0	29,0	86,0	1,150	0,550	17,8	21,7	55,7	15,1
B 37	1	Y 3710	21	550,0	290,0	250,0	12	22,0	205,0	673,1	641,4	12	17,0	29,0	-	109,0	25,0	29,0	86,0	1,580	0,550	22,8	21,7	47,6	15,1
C 37	1	Y 3710	18	580,0	290,0	250,0	12	22,0	205,0	571,5	542,9	12	17,0	29,0	15,0	-	109,0	29,0	80,0	1,060	0,530	15,7	16,8	55,1	8,0
D 37	1	Y 3710	21	550,0	290,0	250,0	12	22,0	205,0	673,1	641,4	12	17,0	29,0	-	109,0	25,0	29,0	80,0	1,500	0,530	20,7	16,8	46,3	8,0
A 40	1	Y 4010	21	680,0	335,0	285,0	10	24,0	235,0	673,1	641,4	12	17,0	54,0	15,0	-	130,0	54,0	76,0	2,510	1,150	27,8	36,7	68,3	1,1
C 40	1	Y 4010	21	680,0	335,0	285,0	10	24,0	235,0	673,1	641,4	12	17,0	54,0	15,0	-	130,0	54,0	76,0	2,400	1,160	25,7	31,8	67,6	7,5
A 43	1	Y 4310	21	680,0	335,0	285,0	18	24,0	235,0	673,1	641,4	12	17,0	45,0	15,0	-	170,0	45,0	125,0	3,470	1,640	38,9	47,9	83,5	21,8
C 43	1	Y 4310	21	680,0	335,0	285,0	18	24,0	235,0	673,1	641,4	12	17,0	45,0	15,0	-	170,0	45,0	125,0	3,280	1,460	35,4	34,8	83,4	8,9

Please consider the explanations of technical data on page 15 ff. Bitte beachten Sie die Erläuterung der technischen Daten ab Seite 15.



GEOMETRIC DATA GEOMETRISCHE DATEN

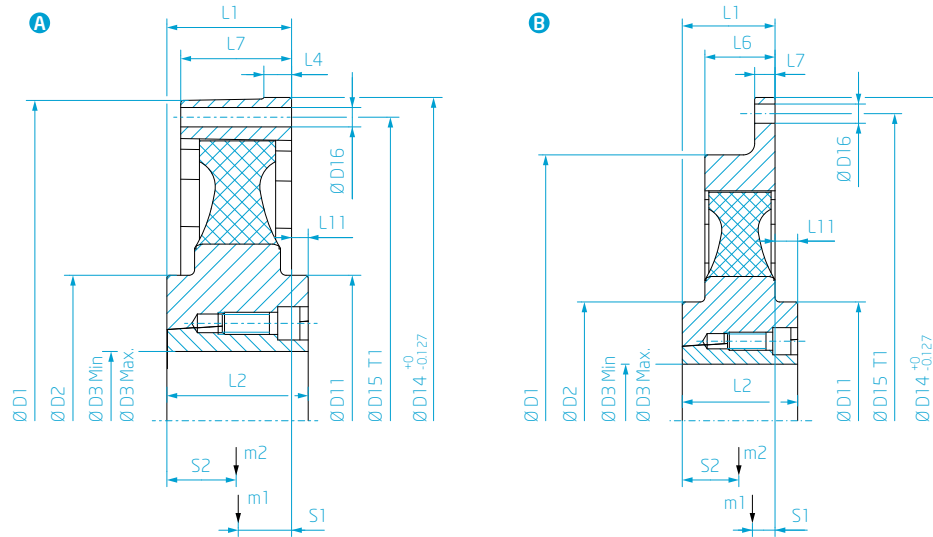

Size code	Element rows	Dimension group	Flywheel	Dimension														Mass moments of inertia		Mass		Distance to center of gravity		
▶ 14 – 22			SAEJ620	D_1	D_2	D_3		D_{11}	D_{14}	D_{15}	T_1	D_{16}	L_1	L_2	L_4	L_6	L_7	L_{11}	J_1	J_2	m_1	m_2	S_1	S_2
▶ 26 – 34			[°]	[mm]	[mm]	[mm]	Min. Max.	[mm]	[mm]	[mm]	[-] Holes	[mm]	[mm]	[mm]	[mm]	[mm]	[mm]	[mm]	[kgm ²]	[kgm ²]	[kg]	[kg]	[mm]	[mm]
A 14	1	Y 1410	8	262,0	-	15,0	50,0	-	263,5	244,5	6	11,0	34,0	32,0	10,0	-	34,0	-	0,020	0,010	1,4	2,8	16,7	16,2
B 14	1	Y 1410	10	265,0	-	15,0	50,0	-	314,4	295,3	8	11,0	34,0	32,0	-	34,0	10,0	-	0,030	0,010	2,1	2,8	13,9	16,2
B 14	1	Y 1410	11½	265,0	-	15,0	50,0	-	352,4	333,4	8	11,0	34,0	32,0	-	34,0	10,0	-	0,050	0,010	2,6	2,8	12,2	16,2
A 16	1	Y 1610	10	312,0	125,0	16,0	60,0	-	314,4	295,3	8	11,0	45,0	45,0	10,0	-	40,0	-	0,040	0,021	2,1	4,9	19,6	23,6
B 16	1	Y 1610	11½	315,0	125,0	16,0	60,0	-	352,4	333,4	8	11,0	45,0	45,0	-	40,0	10,0	-	0,060	0,021	2,8	4,9	17,4	23,6
B 16	1	Y 1610	14	315,0	125,0	16,0	60,0	-	466,7	438,2	8	14,0	45,0	45,0	-	40,0	10,0	-	0,140	0,021	4,6	4,9	12,5	23,6
A 19	1	Y 1910	11½	356,0	155,0	35,0	75,0	-	352,4	333,4	8	11,0	78,0	76,0	12,0	-	48,0	-	0,080	0,056	3,2	9,3	24,7	43,2
B 19	1	Y 1910	14	356,0	155,0	35,0	75,0	-	466,7	438,2	8	14,0	78,0	76,0	-	48,0	12,0	-	0,180	0,056	5,6	9,3	17,4	43,2
B 22	1	Y 2210	14	410,0	180,0	35,0	90,0	180,0	466,7	438,2	8	14,0	77,0	89,0	-	53,0	15,0	12,0	0,220	0,120	6,0	14,6	22,3	46,0

Please consider the explanations of technical data on page 15 ff. Bitte beachten Sie die Erläuterung der technischen Daten ab Seite 15.



GEOMETRIC DATA GEOMETRISCHE DATEN

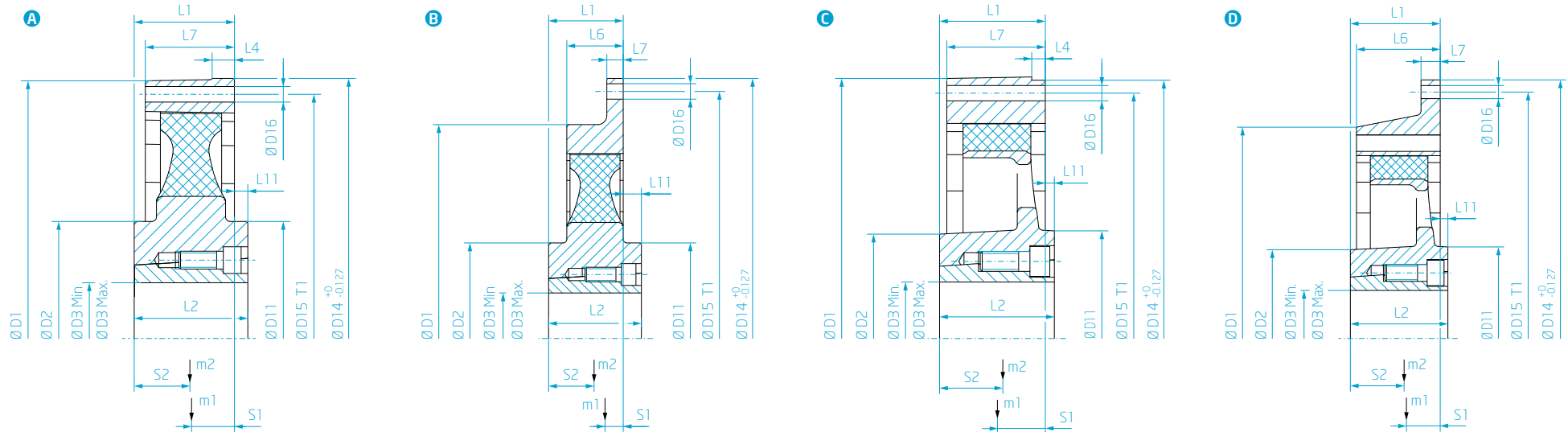

Size code	Element rows	Dimension group	Flywheel	Dimension													Mass moments of inertia		Mass		Distance to center of gravity				
▶ 14 - 22		SAEJ620		D ₁	D ₂	D ₃		D ₁₁	D ₁₄	D ₁₅	T ₁	D ₁₆	L ₁		L ₄	L ₆	L ₇	L ₁₁	J ₁	J ₂	m ₁	m ₂	S ₁	S ₂	
▶ 26 - 34		[°]		[mm]	[mm]	[mm]	[mm]	[mm]	[mm]	[mm]	[mm]	[mm]	[mm]	[mm]	[mm]	[mm]	[mm]	[mm]	[mm]	[kgm ²]	[kgm ²]	[kg]	[kg]	[mm]	[mm]
A	26	1	Y 2610	14	470,0	210,0	40,0	100,0	210,0	466,7	438,2	8	14,0	90,0	102,0	20,0	-	80,0	12,0	0,300	0,240	6,9	22,7	38,5	49,9
B	26	1	Y 2610	18	470,0	210,0	40,0	100,0	210,0	571,5	542,9	12	17,0	82,0	102,0	-	62,0	18,0	20,0	0,600	0,240	11,4	22,7	23,5	49,9
C	26	1	Y 2610	14	470,0	206,0	40,0	100,0	209,0	466,7	438,2	8	14,0	98,0	102,0	20,0	-	80,0	4,0	0,270	0,310	5,9	21,9	38,2	56,9
D	26	1	Y 2610	18	470,0	206,0	40,0	100,0	209,0	571,5	542,9	12	17,0	90,0	102,0	-	62,0	18,0	12,0	0,560	0,310	10,3	22,0	22,7	56,9
A	30	1	Y 3010	14	470,0	-	55,0	110,0	235,0	466,7	438,2	8	14,0	86,0	114,0	20,0	-	80,0	28,0	0,350	0,330	8,1	27,1	39,1	52,5
B	30	1	Y 3010	18	470,0	-	55,0	110,0	235,0	571,5	542,9	12	17,0	86,0	114,0	-	80,0	20,0	28,0	0,660	0,330	12,8	27,1	29,3	52,5
C	30	1	Y 3010	14	470,0	220,0	55,0	110,0	225,0	466,7	438,2	8	14,0	86,0	114,0	20,0	-	80,0	28,0	0,300	0,400	6,4	25,0	39,0	56,0
D	30	1	Y 3010	18	470,0	220,0	55,0	110,0	225,0	571,5	542,9	12	17,0	86,0	114,0	-	80,0	20,0	28,0	0,600	0,400	11,1	25,0	27,8	56,0
A	34	1	Y 3410	18	580,0	280,0	70,0	125,0	280,0	571,5	542,9	12	17,0	117,0	127,0	15,0	-	109,0	10,0	1,080	1,040	16,6	56,5	53,5	62,0
B	34	1	Y 3410	21	550,0	280,0	70,0	125,0	280,0	673,1	641,4	12	17,0	117,0	127,0	-	109,0	25,0	10,0	1,500	1,040	21,3	56,5	45,0	62,0
C	34	1	Y 3410	18	580,0	231,0	70,0	125,0	240,0	571,5	542,9	12	17,0	117,0	127,0	15,0	-	109,0	10,0	1,020	0,630	15,1	31,5	53,4	69,0
D	34	1	Y 3410	21	550,0	231,0	70,0	125,0	240,0	673,1	641,4	12	17,0	117,0	127,0	-	109,0	25,0	10,0	1,440	0,630	19,9	31,5	44,1	69,0

Please consider the explanations of technical data on page 15 ff. Bitte beachten Sie die Erläuterung der technischen Daten ab Seite 15.



GEOMETRIC DATA GEOMETRISCHE DATEN

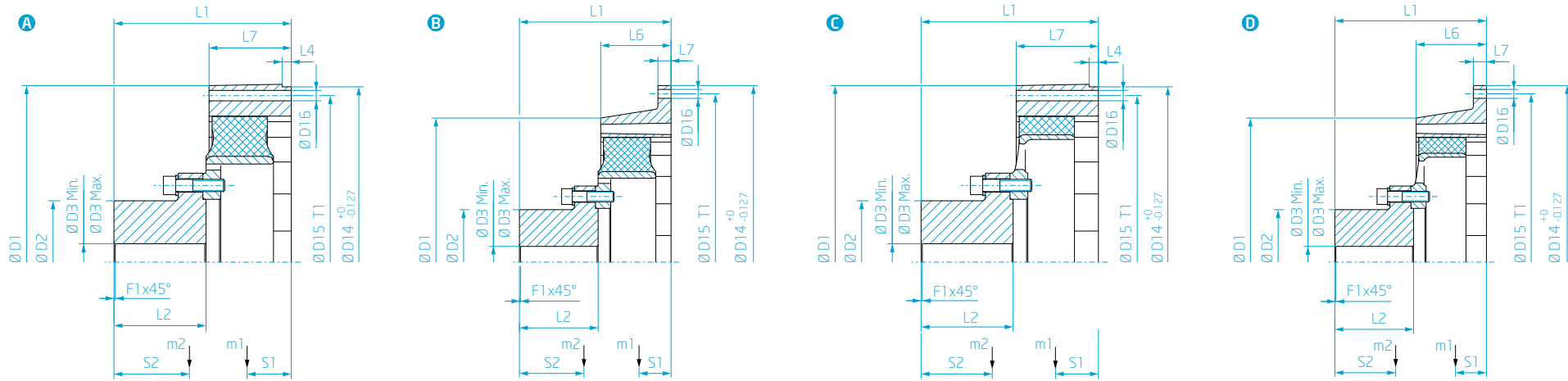

Size code	Element rows	Dimension group	Flywheel	Dimension														Mass moments of inertia		Mass		Distance to center of gravity	
				SAEJ620	D ₁	D ₂	D ₃		D ₁₄	D ₁₅	T ₁	D ₁₆	L ₁	L ₂	L ₄	L ₆	L ₇	F ₁	J ₁	J ₂	m ₁	m ₂	S ₁
▶ 14 - 30	▶ 34 - 43			[°]	[mm]	[mm]	[mm] Min.	[mm] Max.	[mm]	[mm]	[-] Holes	[mm]	[mm]	[mm]	[mm]	[mm]	[mm]	[kgm ²]	[kgm ²]	[kg]	[kg]	[mm]	[mm]
B 14	1	Y 1410	10	265,0	82,0	20,0	58,0	314,4	295,3	8	11,0	127,0	82,0	10,0	49,0	25,0	1,5	0,080	0,010	4,2	5,4	18,4	59,5
B 14	1	Y 1410	11½	265,0	82,0	20,0	58,0	352,4	333,4	8	11,0	180,0	100,0	10,0	49,0	25,0	1,5	0,120	0,020	5,0	7,7	18,0	87,0
B 16	1	Y 1610	11½	315,0	94,0	25,0	68,0	352,4	333,4	8	11,0	190,0	105,0	10,0	55,0	25,0	1,5	0,130	0,030	5,3	10,6	21,2	91,6
B 16	1	Y 1610	14	314,0	94,0	25,0	68,0	466,7	438,2	8	14,0	156,0	105,0	10,0	55,0	25,0	1,5	0,370	0,020	9,3	8,3	17,2	74,9
B 19	1	Y 1910	14	356,0	112,0	35,0	80,0	466,7	438,2	8	14,0	183,0	105,0	10,0	63,0	27,0	1,5	0,420	0,050	10,5	13,9	21,1	86,1
B 22	1	Y 2210	14	410,0	133,0	35,0	95,0	466,7	438,2	8	14,0	190,0	105,0	-	89,0	15,0	1,5	0,290	0,100	7,8	18,2	42,5	77,8
A 26	1	Y 2610	14	470,0	154,0	45,0	110,0	466,7	438,2	8	14,0	201,0	105,0	20,0	-	101,0	1,5	0,440	0,200	9,6	25,6	57,6	79,7
B 26	1	Y 2610	18	470,0	154,0	45,0	110,0	571,5	542,9	12	17,0	201,0	105,0	-	101,0	20,0	1,5	0,760	0,200	14,5	25,6	43,1	79,7
C 26	1	Y 2610	14	470,0	154,0	45,0	110,0	466,7	438,2	8	14,0	201,0	105,0	20,0	-	101,0	1,5	0,410	0,280	8,5	26,7	55,9	80,7
D 26	1	Y 2610	18	470,0	154,0	45,0	110,0	571,5	542,9	12	17,0	201,0	105,0	-	101,0	20,0	1,5	0,730	0,280	13,3	26,7	40,9	80,7
A 30	1	Y 3010	14	470,0	160,0	50,0	115,0	466,7	438,2	8	14,0	260,0	135,0	20,0	-	124,0	2,0	0,570	0,270	12,5	33,0	70,3	105,5
B 30	1	Y 3010	18	470,0	160,0	50,0	115,0	571,5	542,9	12	17,0	260,0	135,0	-	124,0	20,0	2,0	0,880	0,270	17,3	33,0	55,1	105,5
C 30	1	Y 3010	14	470,0	160,0	50,0	115,0	466,7	438,2	8	14,0	260,0	135,0	20,0	-	124,0	2,0	0,520	0,340	10,8	33,0	68,2	103,8
D 30	1	Y 3010	18	470,0	160,0	50,0	115,0	571,5	542,9	12	17,0	260,0	135,0	-	124,0	20,0	2,0	0,830	0,340	15,5	33,0	51,9	103,8

Please consider the explanations of technical data on page 15 ff. Bitte beachten Sie die Erläuterung der technischen Daten ab Seite 15.



GEOMETRIC DATA GEOMETRISCHE DATEN

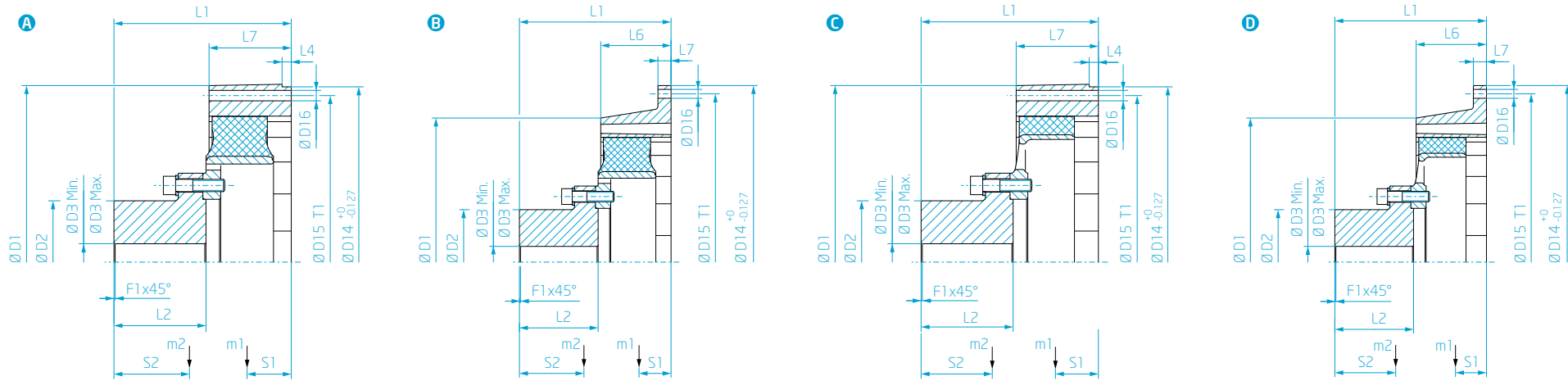

Size code	Element rows	Dimension group	Flywheel	Dimension										Mass moments of inertia		Mass		Distance to center of gravity					
				SAEJ620	D ₁	D ₂	D ₃		D ₁₄	D ₁₅	T ₁	D ₁₆	L ₁	L ₂	L ₄	L ₆	L ₇	F ₁	J ₁	J ₂	m ₁	m ₂	S ₁
▶ 14 - 30				[°]	[mm]	[mm]	[mm] Min.	[mm] Max.	[mm]	[mm]	[-] Holes	[mm]	[mm]	[mm]	[mm]	[mm]	[mm]	[kgm ²]	[kgm ²]	[kg]	[kg]	[mm]	[mm]
A 34	1	Y 3410	18	580,0	185,0	60,0	130,0	571,5	542,9	12	17,0	281,0	150,0	15,0	-	109,0	2,0	1,080	0,850	16,5	62,4	58,6	128,8
B 34	1	Y 3410	21	550,0	185,0	60,0	130,0	673,1	641,4	12	17,0	278,0	150,0	-	109,0	25,0	2,0	1,500	0,850	21,3	62,4	48,3	128,8
C 34	1	Y 3410	18	580,0	185,0	60,0	130,0	571,5	542,9	12	17,0	281,0	150,0	15,0	-	109,0	2,0	1,010	0,880	14,8	60,0	57,3	124,6
D 34	1	Y 3410	21	550,0	185,0	60,0	130,0	673,1	641,4	12	17,0	278,0	150,0	-	109,0	25,0	2,0	1,430	0,880	19,6	60,0	46,7	124,6
A 37	1	Y 3710	18	580,0	200,0	60,0	140,0	571,5	542,9	12	17,0	289,0	150,0	15,0	-	134,0	2,0	1,350	0,920	20,5	64,7	71,7	123,3
B 37	1	Y 3710	21	550,0	200,0	60,0	140,0	673,1	641,4	12	17,0	289,0	150,0	-	134,0	25,0	2,0	1,790	0,920	25,7	64,7	60,9	123,3
C 37	1	Y 3710	18	580,0	200,0	60,0	140,0	571,5	542,9	12	17,0	289,0	150,0	15,0	-	134,0	2,0	1,260	0,890	18,4	59,9	70,3	116,0
D 37	1	Y 3710	21	550,0	200,0	60,0	140,0	673,1	641,4	12	17,0	289,0	150,0	-	134,0	25,0	2,0	0,170	0,890	23,6	59,9	58,9	116,0
A 40	1	Y 4010	21	680,0	205,0	70,0	145,0	673,1	641,4	12	17,0	324,0	175,0	15,0	-	130,0	2,0	2,510	1,770	27,8	94,0	68,3	154,7
C 40	1	Y 4010	21	680,0	205,0	70,0	145,0	673,1	641,4	12	17,0	324,0	175,0	15,0	-	130,0	2,0	2,400	1,780	25,7	89,0	67,6	148,6
A 43	1	Y 4310	21	680,0	238,0	70,0	170,0	673,1	641,4	12	17,0	360,0	190,0	15,0	-	170,0	2,0	3,470	2,470	38,9	122,3	85,6	167,8
C 43	1	Y 4310	21	680,0	238,0	70,0	170,0	673,1	641,4	12	17,0	360,0	190,0	15,0	-	170,0	2,0	3,280	2,290	35,4	109,2	85,1	153,7

Please consider the explanations of technical data on page 15 ff. Bitte beachten Sie die Erläuterung der technischen Daten ab Seite 15.

ONLINE-SERVICE



FOR FURTHER INFORMATION, PLEASE REFER TO OUR WEBSITE WWW.VULKAN.COM WEITERE INFORMATIONEN FINDEN SIE AUF WWW.VULKAN.COM

VULASTIK XT
www.vulkan.com/en-us/couplings/products/highly-flexible-couplings/vulastik-l



VULASTIK XT
www.vulkan.com/de-de/couplings/produkte/hochelastische-kupplungen/vulastik-l

CATALOGUES & BROCHURES
www.vulkan.com/en-us/couplings/downloads-videos



KATALOGE & BROSCHÜREN
www.vulkan.com/de-de/couplings/downloads-videos

VULKAN ENGINEERING PORTAL
www.vulkan.com/en-us/couplings/service/vulkan-engineering-portal



VULKAN ENGINEERING PORTAL
www.vulkan.com/de-de/couplings/service/vulkan-engineering-portal

PRODUCT SELECTOR
www.vulkan.com/en-us/couplings/service/product-selector



PRODUKTSELEKTOR
www.vulkan.com/de-de/couplings/service/produktselektor

AUTHORISED DISTRIBUTORS
www.vulkan.com/en-us/couplings/contact



AUTORISIERTE HÄNDLER
www.vulkan.com/de-de/couplings/kontakt

VIDEOS
www.vulkan.com/en-us/couplings/downloads-videos/videos



VIDEOS
www.vulkan.com/de-de/couplings/downloads-videos/videos



VALIDITY CLAUSE GÜLTIGKEITSKLAUSEL

The containing technical data are valid only for defined areas of applications. In these applications, the couplings do not require acceptance by classification societies in the areas:

- ⊕ Industrial applications such as pumps, fans, compressors, blowers and mobile machinery
- ⊕ Drives for stationary energy production with diesel or gas engines
- ⊕ Drives for energy production with diesel or gas engines in mobile applications such as Trains, mobile machinery and maritime applications

For other than the named applications please contact your local VULKAN supplier for further consideration.

The present catalogue replaces all previous editions, any previous printings are no longer valid. VULKAN reserves the right to amend and change any details contained in this catalogue respectively. The new data shall only apply to couplings that were ordered after said amendment or change. It is the responsibility of the user to ensure that only the latest catalogue issue is used. The latest issue can be found on the website of VULKAN on www.vulkan.com.

The data contained in this catalogue refer to the technical standard as presently used by VULKAN with defined conditions according to the explanations. It is the sole responsibility and decision of the system administrator for the drive line to draw conclusions about the system behaviour.

VULKAN torsional vibration analysis usually only considers the mechanical mass-elastic system. Being a component manufacturer exclusively, VULKAN accepts no system responsibility with the analysis of the torsional vibration system (stationary, transiently). The accuracy of the analysis depends on the exactness of the used data and the data VULKAN is provided with, respectively.

Any changes due to the technological progress are reserved. For questions or queries please contact VULKAN.

Status: 02/2022

All duplication, reprinting and translation rights are reserved. We reserve the right to modify dimensions and constructions without prior notice.

Die enthaltenen technischen Daten sind nur gültig für den Einsatz in definierten Anwendungsgebieten. In diesen Anwendungsgebieten benötigen die Kupplungen keine Abnahme durch Klassifikationsgesellschaften in den Bereichen:

- ⊕ Industrielle Anwendungen wie Pumpen, Lüfter, Kompressoren und mobile Anlagen
- ⊕ Antriebe für stationäre Energieerzeugung mit Diesel- oder Gasmotoren
- ⊕ Antriebe für Energieerzeugung mit Diesel- oder Gasmotoren für mobile Anwendungen wie Züge, Arbeitsmaschinen und Schiffe

Abweichende Anwendungen bedürfen einer individuellen Betrachtung. Bitte kontaktieren Sie hierzu ihren lokalen VULKAN Vertreter.

Die vorliegende Broschüre ersetzt alle vorherigen Ausgaben, ältere Drucke verlieren ihre Gültigkeit. VULKAN ist berechtigt, die in dieser Broschüre enthaltenen Daten entsprechend anzupassen und zu verändern. Die neuen Daten gelten nur für nach der Änderung bestellte Kupplungen. Es liegt im Verantwortungsbereich des Anwenders dafür zu sorgen, dass ausschließlich die aktuelle Katalogversion verwendet wird. Der jeweils aktuelle Stand ist auf der Webseite von VULKAN unter www.vulkan.com jederzeit abrufbar. Die Angaben in dieser Broschüre beziehen sich auf den technischen Standard gültig im Hause VULKAN und gelten unter den in den Erläuterungen definierten Bedingungen. Es liegt allein im Entscheidungs- und Verantwortungsrahmen des Systemverantwortlichen für den Antriebsstrang, entsprechende Rückschlüsse auf das Systemverhalten zu ziehen.

VULKAN Drehschwingungsanalysen berücksichtigen in der Regel nur das rein mechanische Schwingungsersatzsystem. Als reiner Komponentenhersteller übernimmt VULKAN mit der Analyse des Drehschwingungssystems (stationär, transient) nicht die Systemverantwortung. Die Genauigkeit der Analyse hängt von der Genauigkeit der verwendeten bzw. der VULKAN zur Verfügung gestellten Daten ab.

Änderungen aufgrund des technischen Fortschritts sind vorbehalten. Bei Unklarheiten bzw. Rückfragen kontaktieren Sie bitte VULKAN.

Stand: 02/2022

Das Recht auf Vervielfältigung, Nachdruck und Übersetzungen behalten wir uns vor. Maß- und Konstruktionsänderungen vorbehalten.

PUBLISHER:

VULKAN Group

CONCEPT AND DESIGN:

Hackforth Holding GmbH & Co. KG

VULKAN Marketing

Heerstraße 66, 44653 Herne / Germany

E-mail: marketing@vulkan.com

STATUS: 02/2022

All duplication, reprinting and translation rights are reserved. Any changes due to the technological progress are reserved.

For questions or queries please contact VULKAN.